

M 820 / 3000  
M 820 / 3600 (-)

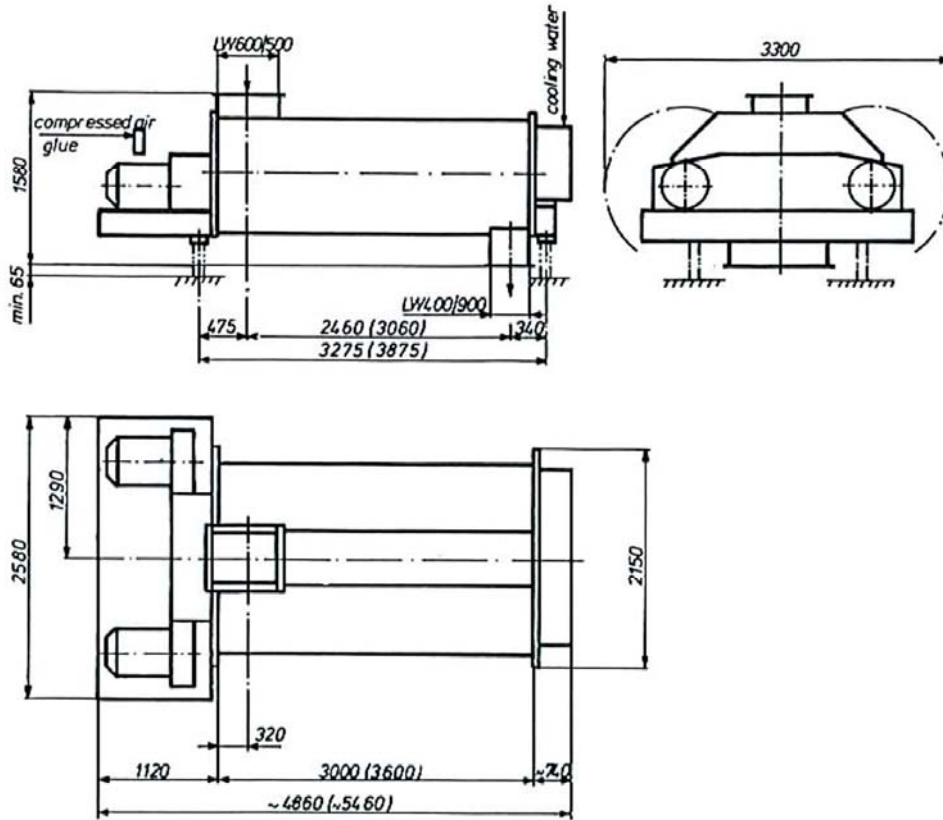

### Technical Data

Type	Capacity DB/hour at a bulk weight of approx. 130 kg/m <sup>3</sup>	Dimension sheet	Power installed	Consumption of cooling water at 8°C	Air consumption at 3 bar m <sup>3</sup> ( standard)	R.P.M. main shafts	Drive of trough doors	Weight incl. main motors
M 400/1750	1500 - 3200 kg	3-040-7-14617	2 x 11 kW 2 x 15 kW	2 m <sup>3</sup> /h	4,5 Nm <sup>3</sup> /h	900 min <sup>-1</sup>	2 x 0,37 kW	approx.1720 kg
M 400/2000	2000 - 4000 kg	3-040-7-14984	2 x 15 kW 2 x 18,5 kW	3 m <sup>3</sup> /h	6 Nm <sup>3</sup> /h	900 min <sup>-1</sup>	2 x 0,37 kW	approx.1900 kg
M 500/2000	2500 - 7000 kg	3-040-7-14613	2 x 18,5 kW 2 x 22 kW	4 m <sup>3</sup> /h	8 Nm <sup>3</sup> /h	800 min <sup>-1</sup>	2 x 0,37 kW	approx.3100 kg
M 500/2500	3500 - 9000 kg	3-040-7-14612	2 x 22 kW 2 x 30 kW	6 m <sup>3</sup> /h	11 Nm <sup>3</sup> /h	800 min <sup>-1</sup>	2 x 0,37 kW	approx.3500 kg
M 650/2500	5000 - 12800 kg	3-040-7-14608	2 x 30 kW 2 x 37 kW	9 m <sup>3</sup> /h	15 Nm <sup>3</sup> /h	650 min <sup>-1</sup>	2 x 0,55 kW	approx.4120 kg
M 650/3000	7000 - 17000 kg	3-040-7-14611	2 x 37 kW 2 x 45 kW	12 m <sup>3</sup> /h	20 Nm <sup>3</sup> /h	650 min <sup>-1</sup>	2 x 0,55 kW	approx.4500 kg
M 820/3000	10000 - 24000 kg	3-040-7-14560	2 x 45 kW 2 x 55 kW	15 m <sup>3</sup> /h	28 Nm <sup>3</sup> /h	520 min <sup>-1</sup>	2 x 0,55 kW	approx.6000 kg
M 820/3600	14000 - 32000 kg	3-040-7-14563	2 x 75 kW	20 m <sup>3</sup> /h	45 Nm <sup>3</sup> /h	520 min <sup>-1</sup>	2 x 0,55 kW	approx.6800 kg

Remarks: Temperature increase of the cooling water  $\Delta t = 4^\circ$  to  $5^\circ$  C depending on machine load